

# Holdback Clutches

## LLH® (Long Life Holdbacks®)

### Backstopping Technology

Formsprag offers two technologies in backstopping designs, Sprag and Ramp & Roller. The sprag design is comprised of a full complement of accurately formed sprags filling the annular space. The ramp & roller design consists of precision-machined ramps on the inner race and bearing quality cylindrical rollers filling the annular space.

In backstopping or holdback applications, one race is always fixed to a stationary ground member. The function of the holdback clutch is to permit rotation of the mechanism connected to the inner race in one direction only, and to prevent rotation in the reverse direction at any time. Although the clutch normally overruns most of the time, it is referred to as a holdback or backstop in conveyors, gear reducers and similar equipment, because its function is to prevent reverse rotation.

LLH holdback clutches are ready to install. They are equipped with a one-piece, quickly detachable torque arm (simply remove two pins), and grease labyrinth protected oil seals that positively prevent airborne contaminants from reaching internal seals and parts. Oil lubricated, the clutch assembly also includes an oil sight gauge with filter breather, for ease in checking lubricant level. These clutches are designed to be mounted on a through shaft, with the inner race driven by a key. Standard keys are supplied by Formsprag with all holdbacks at no additional charge.

### Sprag Design (Models LLH-700S through LLH-5000S)

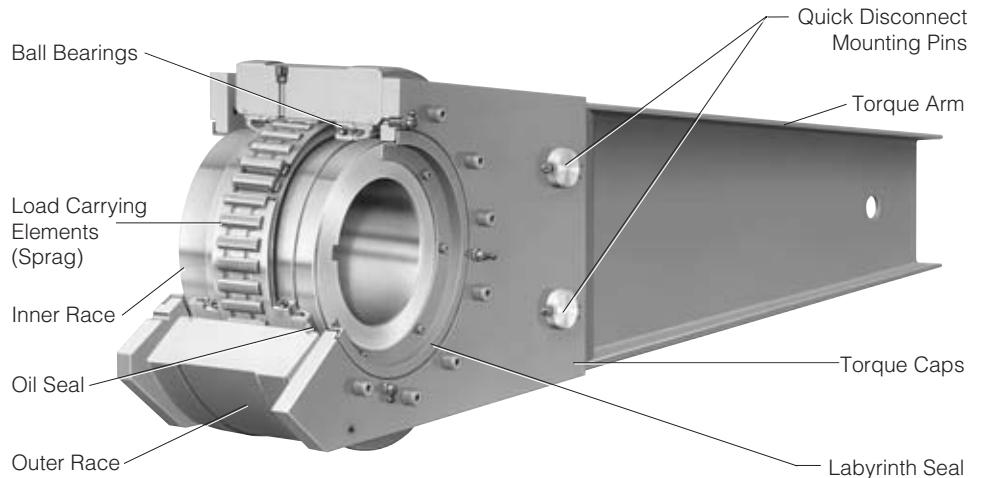

### Ramp and Roller Design (Models LLH-1250R through LLH-5500R)

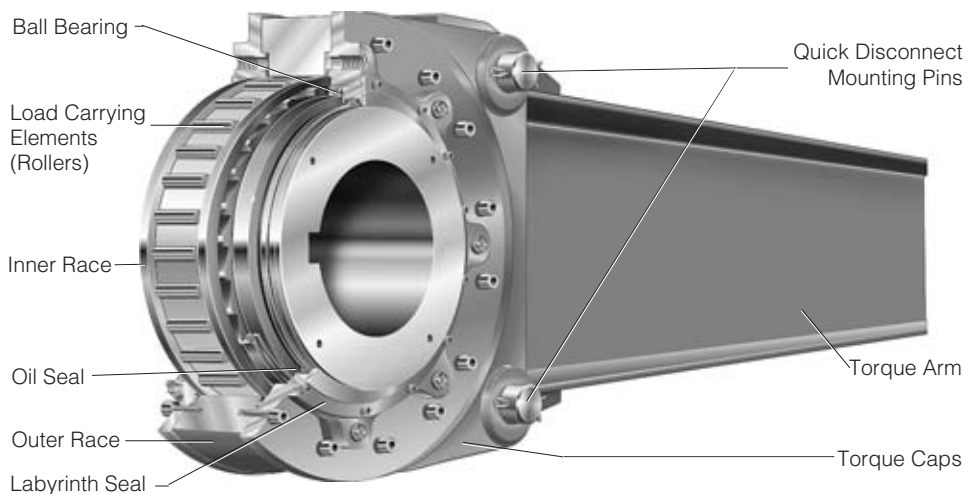

### Typical Holdback Specifications

1. Holdbacks installed on elevators and inclined conveyors must have adequate torque capacity to prevent runback, and must comply with the holdback manufacturer's recommended practice in the selection and application of a safe size.
2. The sprags within the holdback must be positioned and individually energized within a suitable retainer. Sprags must act independent of the retainer and independent of the action of any other sprag.
3. The sprags and the bearings within the holdback must be lubricated with lubricant suitable for the applicable extremes of ambient temperatures. The lubrication system must incorporate a transparent area suitable for visual checking of the oil level at approximately the level of the centerline of the shaft, suitable fitting for draining oil from the holdback, means for filling the holdback with oil, and a breather to relieve pressure within the holdback. The breather must be equipped with a renewable filter arranged to prevent entry of foreign matter into the lubrication system. The breather and filter may be incorporated into the oil filling fitting. An oil seal must be installed externally of each bearing.
4. For dusty or abrasive atmospheres the holdbacks must be equipped with a grease-filled labyrinth seal external to each oil seal. A sufficient number of grease fittings must be provided to insure complete filling and purging of the labyrinth.
5. The holdback must be symmetrical to permit field installation for either direction of rotation without disassembly of the sealed holdback assembly.

### Specifications

Size	Torque Capacity lb.ft. (Nm)	Maximum Overrunning Speed RPM	Resistance after run-in lb.ft. (Nm)	Bore Range Available		Shipping Weight lb. (kg)
				Min. in. (mm)	Max. in. (mm)	
700	4,000 (5440)	400	2.63 (3.57)	1.875 (47.63)	2.937 (74.60)	160 (72)
750	6,800 (9248)	380	3.75 (5.09)	2.250 (57.15)	3.437 (87.30)	215 (97)
800	11,500 (15640)	300	5.25 (7.12)	2.625 (66.68)	4.437 (112.70)	325 (147)
900	18,000 (24480)	250	6.25 (8.48)	3.625 (92.08)	5.437 (138.10)	570 (258)
1027	27,000 (36720)	200	10 (13.56)	4.937 (125.40)	7.000 (177.80)	750 (340)
1051	45,000 (61200)	200	12 (16.27)	4.937 (125.40)	7.000 (177.80)	800 (363)
1250	65,000 (88400)	170	15 (20.34)	6.750 (171.45)	9.000 (228.60)	1,400 (633)
1300	90,000 (122400)	140	28 (37.97)	7.937 (201.60)	10.000 (254.00)	1,700 (770)
1375	135,000 (183600)	130	39 (52.87)	8.937 (227.00)	11.000 (279.40)	2,200 (995)
2000	200,000 (272000)	100	80 (108.48)	10.937 (277.80)	13.250 (336.55)	3,200 (1452)
2400	265,000 (360400)	85	100 (135.60)	13.000 (330.20)	15.500 (393.70)	4,200 (1905)
3500	375,000 (510000)	80	120 (162.72)	13.437 (341.30)	20.000 (508.00)	5,850 (2653)
5000	700,000 (952000)	75	125 (169.50)	13.437 (341.30)	20.000 (508.00)	5,930 (2690)

6. The holdback must be equipped with torque arm securely fastened to the outer race of the clutch. The outer end of the torque arm must be restrained by means that allow the arm to float while preventing rotation of the outer race.
7. The torque and speed capacity specified by the holdback manufacturer must be based upon adequate tests and engineering documentation. Since these units are used as safety devices, an adequate design safety factor must be used. The compressive stress used in the Hertz stress equations will not exceed 450,000 psi.
8. Load carrying elements in the holdbacks will preferably be manufactured from steel forgings, extrusions or bar stock.
9. To assure that proper heat treatment has been given to the holdback parts, relative to hardness, case depth and micro-structure, a certificate of quality attesting to proper metallurgical examination of the above mentioned items by the holdback manufacturer's laboratory will be provided to the purchaser.

# Holdback Clutches

## LLH

### Application Information

Formsprag Long Life Holdbacks are designed to “holdback” reverse torque. They are commonly used on inclined conveyors, bucket elevators, or pumps. Holdbacks have also been used on people moving systems, such as ski lifts and elevators. Specially designed nuclear holdbacks are currently installed on vertical shaft applications in several nuclear power plants with a required 40-year life.

**Torque Arm Mounting Positions** — With standard oil sight gauges, the preferred torque arm mounting position is

approximately horizontal or slightly off of vertical. For installations requiring torque arms oriented in some other position, consult Formsprag.

**Axial Retention Collars** — Formsprag recommends that holdbacks be axially restrained on the shaft. The preferred method of accomplishing this is with set collars (see page 114). Any type of axial restraint applied to the torque arm reaction end will result in uneven bearing loads that will greatly reduce the bearing B-10 life. Restraint keys are also available. See page 115.

### Typical Conveyor Holdback Arrangements

#### Single Head Pulley Drive

Locate the holdback on the opposite end of the head pulley drive shaft from the drive motor, speed reducer and coupling.

There are two rules for selecting holdbacks:

1. The holdback should always be mounted on the drive shaft.
2. The torque capacity of the holdback should be equal to or greater than the rated capacity of the drive motor.

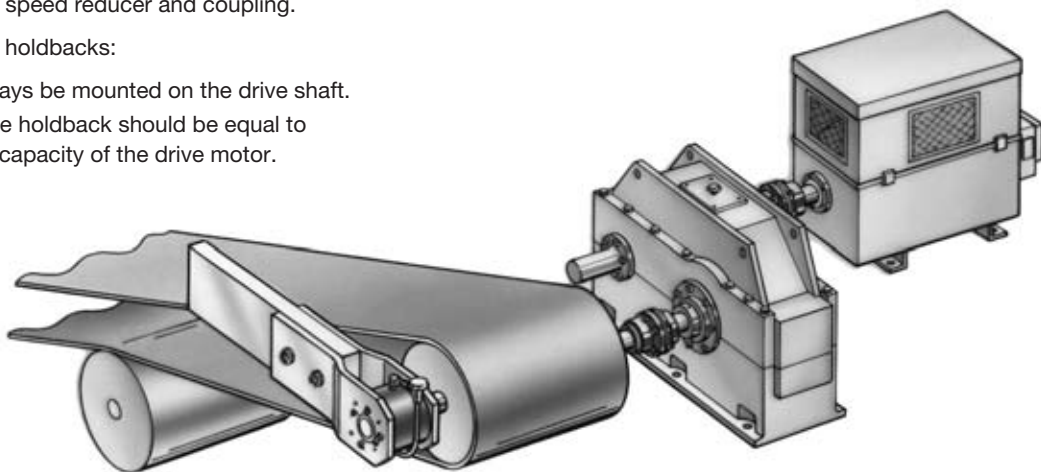
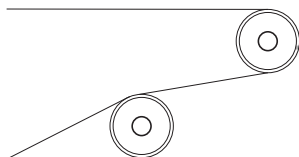

#### Single Drive Pulley Other Than Head Pulley

Locate the holdback on the drive pulley shaft, at the opposite end from the drive motor, speed reducer and coupling.

There are two rules for selecting holdbacks:

1. The holdback should always be mounted on the drive shaft.
2. The torque capacity of the holdback should be equal to or greater than the rated capacity of the drive motor.

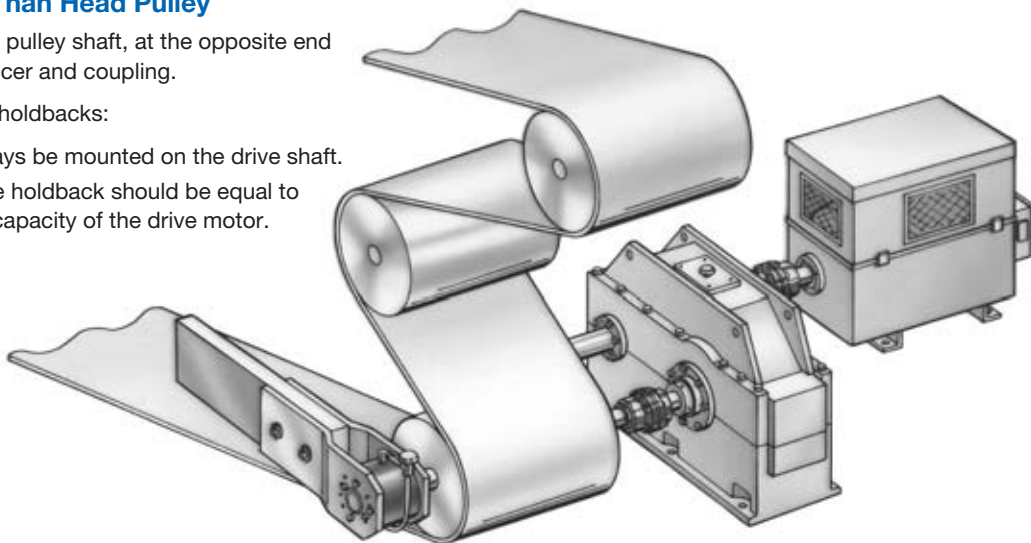
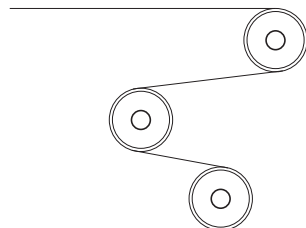

**Auxiliary Seals** — All Formsprag holdbacks are furnished with two grease labyrinth-type seals. These seals, when purged with fresh grease periodically in accordance with our maintenance instructions, will protect the clutch against dusty or abrasive environments.

**Operating Temperatures** — For temperatures above 200°F consult Formsprag.

**Standard Supplied Keys** — All holdbacks are furnished with a hardened (25 – 40Rc) key. Customers should check key and

shaft stress before making final clutch selection since this may determine the maximum allowable drive torque capacity. Do not drive or press-fit the key. It should be installed in the shaft keyway with a “push” fit.

**Extended Storage** — If holdbacks are kept out of operation for six months or more, they should be flushed out and relubricated prior to operation. If holdbacks are to be stored over an extended period of time, consult Formsprag for specific preservation and packaging instructions. See page 77 for extended storage.

### Single Pulley With Dual Drive

Contact Formsprag for selection information on other possible holdback mounting arrangements.

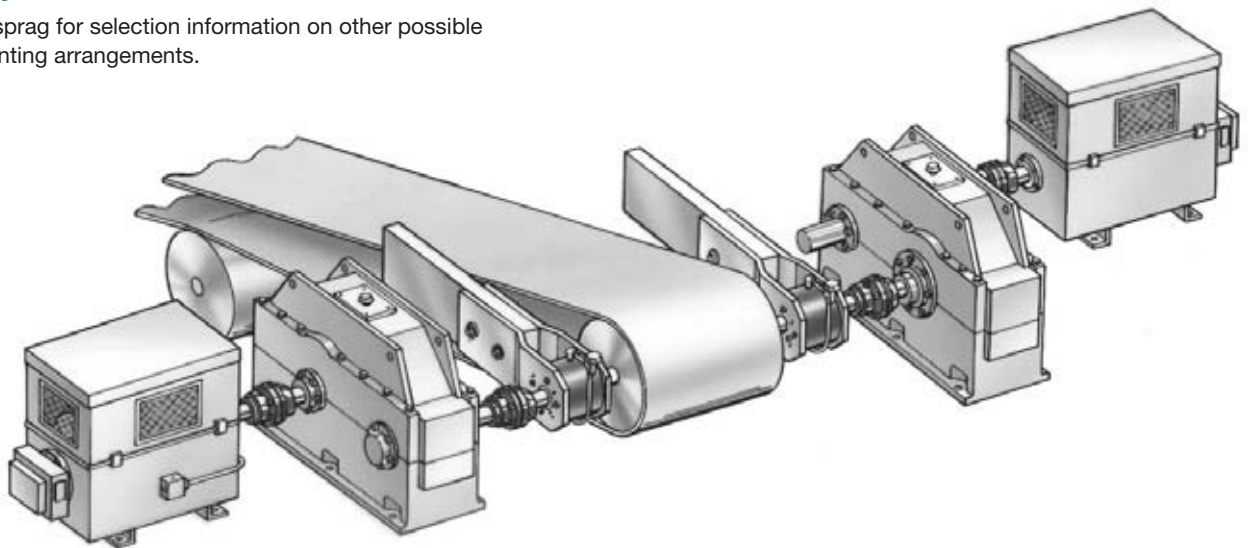

### Tandem Drive Pulleys

Contact Formsprag for selection information on other possible holdback mounting arrangements.

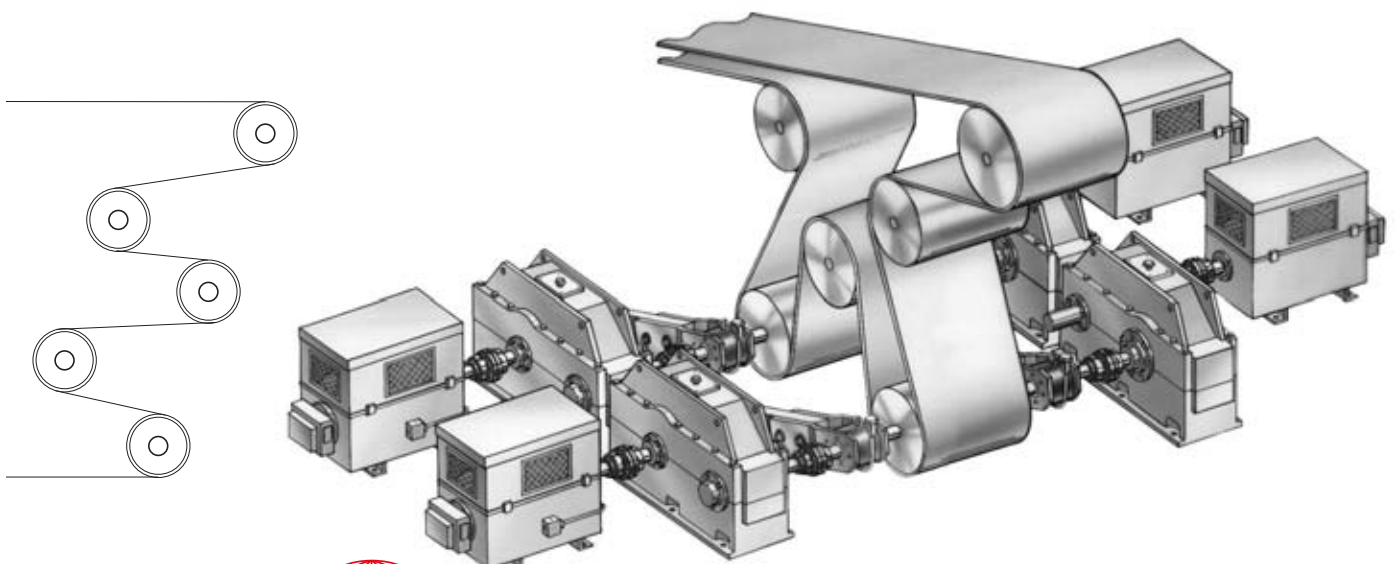

**Model sizes 700 through 900**

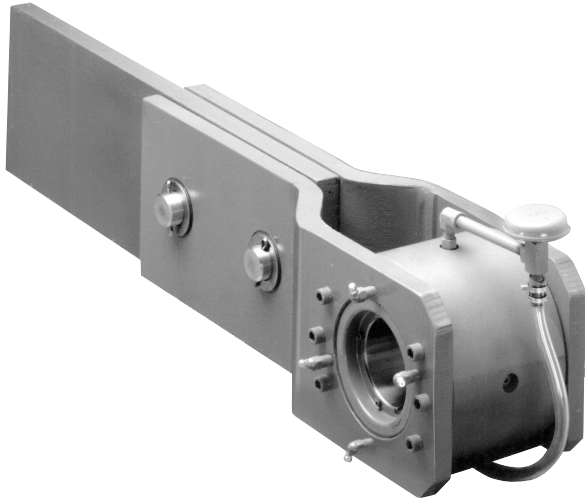

**Horizontal Mounting**

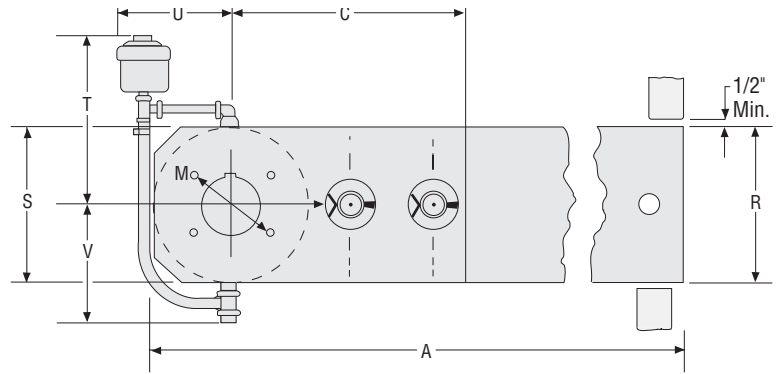

**Sizes 700 through 800**

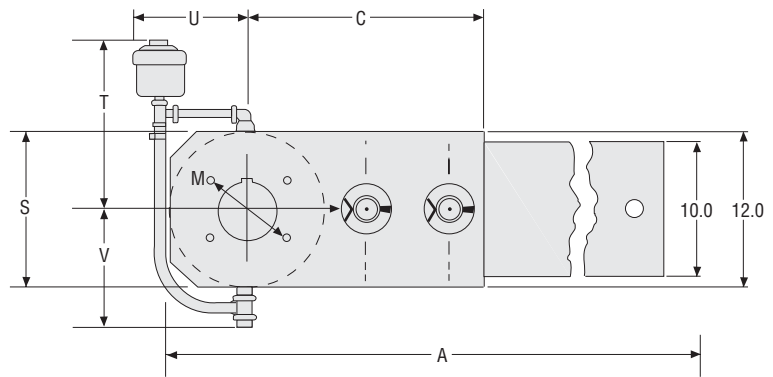

**Size 900**

**Dimensions** inches (mm)

Size	A	B	C	F	G	H	J	L	M	N	P
700	33.63 (854.07)	30.00 (762.00)	18.00 (457.20)	8.25 (209.55)	7.13 (180.97)	6.38 (161.92)	5.00 (127.00)	3.63 (92.07)	5.31 (134.92)	3.88 (98.42)	2.50 (63.50)
750	36.38 (923.92)	32.00 (812.80)	20.38 (517.52)	9.25 (234.95)	8.38 (212.72)	7.38 (187.32)	6.00 (152.40)	4.63 (117.47)	5.81 (147.62)	3.88 (98.42)	2.50 (63.50)
800	37.00 (939.80)	32.00 (812.80)	22.13 (561.97)	9.50 (241.30)	8.63 (219.07)	7.63 (193.67)	6.00 (152.40)	5.44 (138.10)	7.31 (185.72)	4.19 (106.35)	2.75 (69.85)
900	50.00 (1270.00)	44.00 (1117.60)	22.75 (577.85)	9.75 (247.65)	9.25 (234.95)	8.00 (203.20)	6.38 (161.92)	6.44 (163.50)	8.56 (217.47)	4.69 (119.05)	3.25 (82.55)



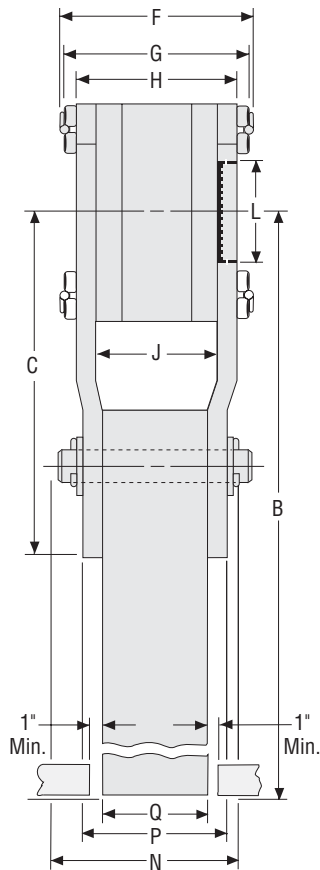

Sizes 700 through 900

Dimensions inches (mm)

Size	Q	R	S	T	U	V
700	1.00 (25.40)	7.00 (177.80)	7.13 (180.97)	6.00 (152.40)	6.00 (152.40)	5.00 (127.00)
750	1.00 (25.40)	8.00 (203.20)	8.00 (203.20)	11.50 (292.10)	7.25 (184.15)	7.25 (184.15)
800	1.00 (25.40)	10.00 (254.00)	10.00 (254.00)	12.50 (317.50)	8.00 (203.20)	7.75 (196.85)
900	1.50 (38.10)	10.00 (254.00)	10.00 (254.00)	13.50 (342.90)	9.25 (234.95)	8.75 (222.25)

Bore sizes and keyseats\* inches (mm)

Size	Bore Size	Keyseat	Bore Range	
			Min.	Max.
700	1.937 (49.20)	1/2 x 1/4 (12.70 x 6.35)	1.875 (47.62)	3.250 (74.60)
	2.000 (50.80)			
	2.250 (57.15)			
	2.437 (61.90)	5/8 x 5/16 (15.87 x 7.93)		
	2.500 (63.50)			
	2.750 (69.85)	5/8 x 7/32 (15.87 x 5.56)		
2.937 (74.60)	5/8 x 1/8 (15.87 x 3.18)			
750	2.437 (61.90)	5/8 x 5/16 (15.87 x 7.93)	2.250 (57.15)	3.437 (87.30)
	2.500 (63.50)			
	2.750 (69.85)			
	2.937 (74.60)	3/4 x 3/8 (19.05 x 9.52)		
	3.000 (76.20)			
	3.250 (82.55)	3/4 x 1/4 (19.05 x 6.35)		
3.437 (87.30)	3/4 x 3/16 (19.05 x 4.75)			
800	2.937 (74.60)	3/4 x 3/8 (19.05 x 9.52)	2.625 (66.67)	4.437 (112.70)
	3.000 (76.20)			
	3.250 (82.55)			
	3.437 (87.30)	7/8 x 7/16 (22.22 x 11.10)		
	3.500 (88.90)			
	3.750 (95.25)			
3.937 (100.00)	1 x 1/2 (25.40 x 12.70)			
4.000 (101.60)				
4.250 (107.95)	1 x 3/8 (25.40 x 9.52)			
4.437 (112.70)	1 x 1/4 (25.40 x 6.35)			
900	3.937 (100.00)	1 x 1/2 (25.40 x 12.70)	3.625 (92.07)	5.437 (138.10)
	4.000 (101.60)			
	4.250 (107.95)			
	4.437 (112.70)	1 x 3/8 (25.40 x 9.52)		
	4.500 (114.30)			
	4.750 (120.65)			
4.937 (125.40)	1 x 1/4 (25.40 x 6.35)			
5.000 (127.00)				
5.250 (133.35)				
5.437 (138.10)				



INDUSTRIAL MAGZA

MEX (55) 53 63 23 01 - MTY (81) 83 54 10 18

QRO (442) 1 95 72 60 - Venas Industrial Magza.com

**Model Sizes 1027 Through 5000**

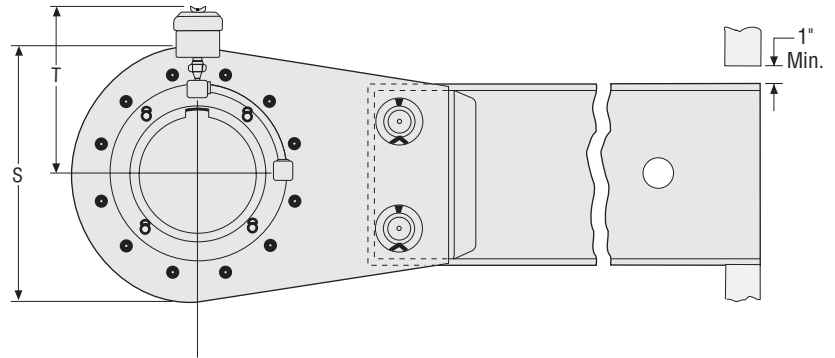
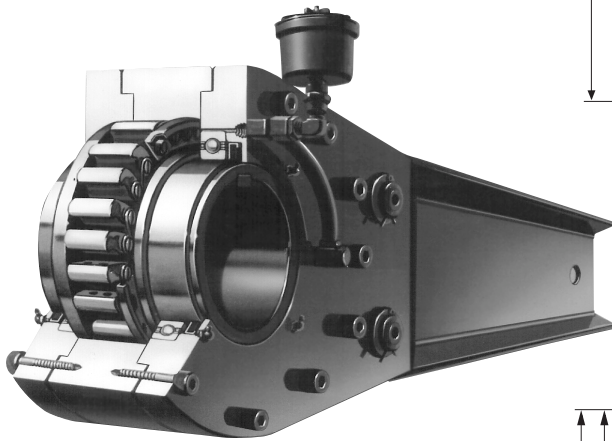

**Horizontal Mounting**

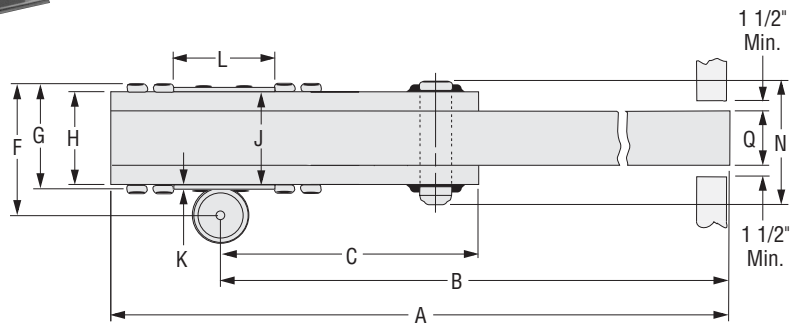

**Dimensions inches (mm)**

Size	A	B	C	F	G	H	J	K	L	M	N
1027	68.63 (1743.55)	61.88 (1571.62)	18.00 (457.20)	9.63 (244.47)	9.50 (241.30)	8.25 (209.55)	6.63 (168.27)	—	8.88 (225.42)	10.75 (273.05)	10.00 (254.00)
1051	68.63 (1743.07)	61.13 (1552.57)	18.00 (457.20)	14.25 (361.95)	10.75 (273.05)	9.50 (241.30)	9.63 (244.47)	0.06 (1.57)	8.63 (219.07)	9.63 (244.47)	11.88 (301.62)
1250	76.00 (1930.40)	66.00 (1676.40)	20.25 (514.36)	14.97 (380.24)	11.57 (293.88)	9.80 (248.92)	10.25 (260.35)	.23 (5.84)	10.56 (268.22)	12.00 (304.80)	12.00 (304.80)
1300	77.75 (1974.85)	67.00 (1701.80)	21.81 (553.97)	15.10 (383.54)	11.87 (300.23)	9.80 (248.92)	10.25 (260.35)	.23 (5.84)	11.72 (297.69)	13.00 (330.20)	12.00 (304.80)
1375	82.25 (2089.15)	70.00 (1778.00)	24.50 (622.30)	15.22 (386.59)	12.07 (306.58)	9.80 (248.92)	11.00 (279.40)	.61 (15.494)	13.56 (344.42)	15.00 (381.00)	12.00 (304.80)
2000	97.00 (2463.80)	82.00 (2082.80)	29.44 (747.70)	15.38 (390.52)	12.38 (314.32)	10.38 (263.52)	10.62 (269.8)	0.13 (3.17)	17.56 (446.07)	19.25 (488.95)	13.00 (330.20)
2400	100.50 (2552.70)	82.50 (2095.50)	34.19 (868.35)	15.38 (390.52)	12.38 (314.32)	10.63 (269.87)	10.88 (276.22)	0.13 (3.17)	19.56 (496.87)	21.25 (539.75)	13.25 (336.55)
3500	101.50 (2578.10)	82.50 (2095.50)	34.12 (866.65)	20.16 (512.06)	17.00 (431.80)	14.75 (374.65)	18.00 (457.20)	1.03 (26.16)	22.46 (570.48)	26.00 (660.40)	16.75 (425.45)
5000	101.50 (2578.10)	82.50 (2095.50)	34.12 (866.65)	24.66 (626.36)	21.50 (546.10)	19.25 (488.95)	22.81 (579.37)	1.03 (26.16)	22.46 (570.48)	26.00 (660.40)	21.25 (539.75)



MEX (55) 53 63 23 31 MTY (81) 83 54 10 18  
 QRO (442) 1 95 72 60 ventas@industrialmagza.com

**Warner Electric/Formspag (800-927-3262) www.formspag.com**

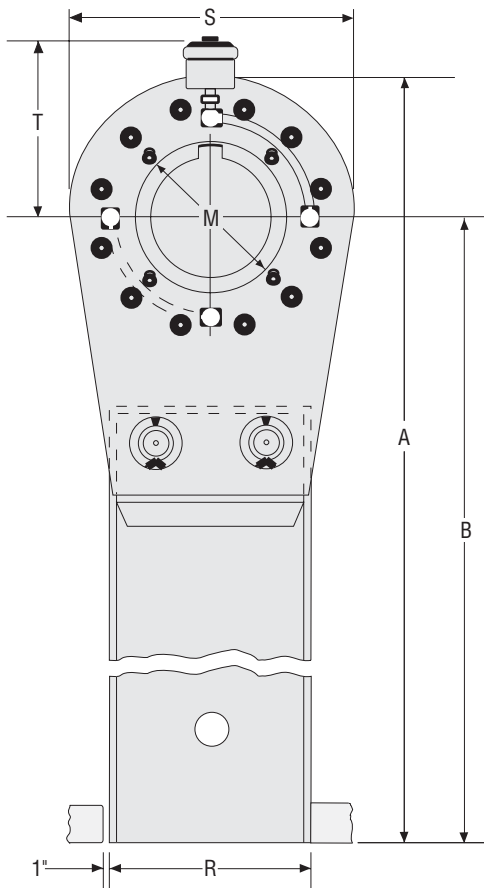

**Vertical Mounting**

(Must be mounted at least 10° off of vertical)

**Dimensions inches (mm)**

Size	P*	Q	R	S	T
1027	8.25 (209.55)	5.25 (133.35)	12.00 (304.80)	15.00 (381.00)	14.50 (368.30)
1051	9.50 (241.30)	5.25 (133.35)	12.00 (304.80)	15.00 (381.00)	12.00 (304.80)
1250	—	5.50 (139.70)	15.00 (381.00)	20.00 (508.00)	13.17 (334.52)
1300	—	6.25 (158.75)	18.00 (457.20)	21.50 (546.10)	13.42 (340.87)
1375	—	6.25 (158.75)	18.00 (457.20)	24.50 (622.30)	14.55 (369.57)
2000	—	7.13 (180.97)	24.00 (609.60)	30.00 (762.00)	17.25 (438.15)
2400	—	7.88 (200.02)	24.00 (609.60)	36.00 (914.40)	18.75 (476.25)
3500	—	8.00 (203.20)	24.00 (609.60)	38.00 (965.20)	20.17 (512.32)
5000	—	8.00 (203.20)	24.00 (609.60)	38.00 (965.20)	20.17 (512.32)

\* Width over torque cap, see page 69.

**Bore sizes and keyseats\*\* inches (mm)**

Size	Bore Size	Keyseat	Bore Range	
			Min.	Max.
1027	4.937 (125.40) to 6.000 (152.40)	1 1/4 x 5/8 (31.75 x 15.87)	4.937 (125.40)	7.000 (177.80)
	6.250 (158.75) to 6.500 (165.10)	1 1/2 x 1/2 (38.10 x 12.70)		
	6.750 (171.45) to 7.000 (177.80)	1 1/2 x 7/16 (38.10 x 11.10)		
1051	5.000 (127.00) to 6.000 (152.40)	1 1/4 x 5/8 (31.75 x 15.88)	4.937 (125.40)	7.000 (177.80)
	6.250 (158.75) to 6.625 (162.28)	1 1/2 x 5/8 (38.10 x 15.88)		
	6.750 (171.45) to 6.875 (174.63)	1 1/2 x 1/2 (38.10 x 12.70)		
	7.000 (177.80)	1 1/2 x 7/16 (38.10 x 11.11)		
1250	7.50 (190.50) to 7.937 (201.60)	1 3/4 x 7/8 (44.45 x 22.35)	6.750 (171.45)	9.000 (228.60)
	8.000 (203.20) to 8.250 (209.55)	1 3/4 x 5/8 (44.45 x 16.00)		
	8.312 (211.12) to 9.000 (228.60)	1 1/2 x 1/2 (38.10 x 12.70)		
	8.000 (203.20) to 9.000 (228.60)	1 3/4 x 7/8 (44.45 x 22.35)		
1300	9.000 (228.60) to 10.000 (254.00)	1 1/2 x 1/2 (38.10 x 12.70)	7.937 (201.60)	10.000 (254.00)
	8.000 (203.20) to 9.000 (228.60)	1 3/4 x 7/8 (44.45 x 22.35)		
	9.063 (230.20) to 10.000 (254.00)	1 1/2 x 1/2 (38.10 x 12.70)		
1375	9.000 (228.60) to 10.250 (260.35)	1 3/4 x 7/8 (44.45 x 22.35)	8.937 (227.00)	11.000 (279.40)
	10.312 (261.93) to 11.000 (279.40)	2 x 3/4 (50.80 x 19.05)		
	10.937 (277.80) to 12.000 (304.80)	2 1/2 x 1 1/4 (63.50 x 31.75)		
2000	12.063 (306.40) to 13.250 (336.55)	2 1/2 x 1 (63.50 x 25.40)	10.937 (277.80)	13.250 (336.55)
	13.000 (330.20) to 15.000 (381.00)	2 1/2 x 1 1/4 (63.50 x 31.75)		
	15.063 (382.60) to 15.500 (393.70)	2 1/2 x 1 (63.50 x 25.40)		
2400	13.437 (341.30) to 13.750 (349.25)	2 1/2 x 1 1/4 (63.50 x 31.75)	13.437 (341.30)	20.00 (508.00)
	14.000 (355.60) to 18.000 (457.20)	3 x 1 1/2 (76.20 x 38.10)		
	20.000 (508.00)	3 x 1 1/4 (76.20 x 31.75)		
3500	13.437 (341.30) to 13.750 (349.25)	2 1/2 x 1 1/4 (63.50 x 31.75)	13.437 (341.30)	20.00 (508.00)
	14.000 (355.60) to 18.000 (457.20)	3 x 1 1/2 (76.20 x 38.10)		
	20.000 (508.00)	3 x 1 1/4 (76.20 x 31.75)		
5000	13.437 (341.30) to 13.750 (349.25)	2 1/2 x 1 1/4 (63.50 x 31.75)	13.437 (341.30)	20.00 (508.00)
	14.000 (355.60) to 18.000 (457.20)	3 x 1 1/2 (76.20 x 38.10)		
	20.000 (508.00)	3 x 1 1/4 (76.20 x 31.75)		



MEX (55) 53 63 23 37 QRO (442) 1 95 15 00 1 83 52 10 1 8



**Model Sizes 1250R Through 5500R**

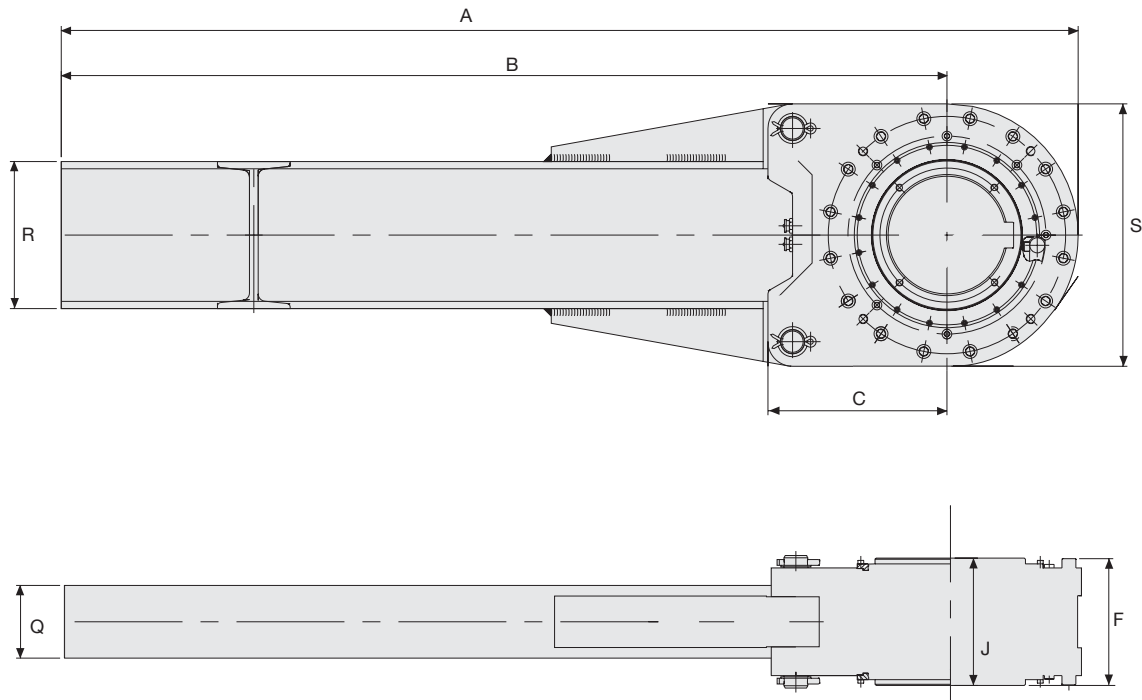

**Dimensions** inches (mm)

Model No.	Torque Capacity	Maximum Overrunning Speed	A	B	C	F	J	Shipping Weight
1250R	63,000 (85909)	120	87.44 (2221)	77.95 (1980)	12.25 (311)	9.3 (236)	9.3 (236)	830 (381)
1300R	90,000 (122040)	105	91.89 (2334)	81.89 (2080)	14.25 (362)	10.5 (267)	10.5 (267)	1,130 (520)
1375R	135,000 (183060)	90	99.61 (2530)	87.99 (2235)	16.06 (408)	11.75 (298)	11.75 (298)	1,500 (690)
2000R	180,000 (244407)	80	107.72 (2736)	94.09 (2390)	16.54 (420)	12.6 (320)	12.6 (320)	2,100 (966)
2400R	240,000 (325,396)	70	115.16 (2925)	100.00 (2540)	18.0 (457)	16.0 (406)	16.0 (406)	2,700 (1242)
3500R	375,000 (508432)	60	138.89 (3528)	120.00 (3048)	23.0 (584)	18.75 (476)	18.7 (476)	6,000 (2760)
5000R	540,000 (732142)	60	166 (4216)	144 (3658)	26.50 (673)	22.5 (572)	22.5 (572)	9,000 (4140)
5500R	720,000 (976271)	60	166 (4216)	144 (3658)	26.50 (673)	23.5 (597)	23.5 (597)	10,000 (4545)

\* Torque arm I-beam. S-type section dimensions may vary according to the American Iron and Steel Institute or DIN standards.

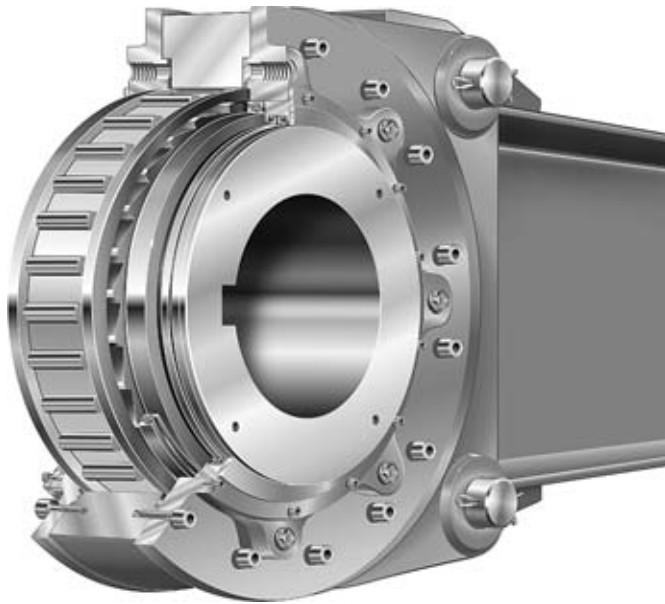

### Bore sizes and keyseats\*\* inches (mm)

Model No.	Bore Size	Keyseat	Bore Range	
			Min.	Max.
1250R	6.000 (152.00) to 6.500 (165.10)	1.500 x .75 (38.10 x 19.05)	5.25 (133.35)	8.000 (203.2)
	6.563 (166.70) to 7.500 (190.50)	1.750 x .75 (44.45 x 15.88)		
	7.563 (192.10) to 8.250 (209.55)	2.000 x .75 (50.80 x 19.05)		
1300R	6.500 (165.10)	1.500 x .75 (38.10 x 12.70)	5.75 (146.05)	9.000 (230.00)
	6.563 (166.70) to 7.500 (190.50)	1.750 x .75 (44.45 x 19.05)		
	7.563 (192.10) to 8.750 (222.25)	2.000 x .75 (50.80 x 19.05)		
1375R	7.750 (196.85) to 9.000 (228.60)	2.000 x .75 (50.80 x 19.05)	6.75 (171.45)	10.500 (270.00)
	9.063 (230.20) to 10.250 (260.35)	2.500 x .88 (63.50 x 22.23)		
2000R	9.000 (228.60)	2.000 x .75 (50.80 x 19.05)	7.25 (184.15)	11.75 (298.45)
	9.063 (230.20) to 11.000 (279.40)	2.500 x .88 (63.50 x 22.23)		
	11.063 (281.00) to 12.000 (304.80)	.000 x 1.00 (76.20 x 25.40)		
2400R	10.500 (266.70) to 11.000 (279.40)	2.500 x .88 (63.50 x 22.23)	8.25 (209.55)	14.000 (360.00)
	11.063 (281.00) to 13.000 (330.20)	3.000 x 1.00 (76.20 x 25.40)		
	13.063 (331.80) to 13.750 (249.25)	3.500 x 1.25 (88.90 x 31.75)		
3500R	13.000 (330.20)	3.000 x 1.00 (76.20 x 25.40)	10.25 (260.35)	18.00 (457.20)
	13.063 (331.80) to 15.000 (381.00)	3.500 x 1.25 (88.90 x 31.75)		
	15.063 (382.60) to 17.000 (431.80)	4.000 x 1.50 (101.60 x 38.10)		
5000R and 5500R	13.000 (330.20)	3.000 x 1.00 (76.20 x 25.40)	15.25 (387.35)	21.00 (533.40)
	13.063 (331.80) to 15.000 (381.00)	3.500 x 1.25 (88.90 x 31.75)		
	15.063 (382.60) to 18.000 (457.20)	4.000 x 1.50 (101.60 x 38.10)		
	18.063 (458.80) to 22.000 (558.80)	5.000 x 1.75 (127.00 x 44.45)		
	22.063 (560.40) to 21.000 (533.4)	6.000 x 4.00 (152.40 x 101.60)		

### Dimensions inches (mm)

Model No.	Q*	R*	S
1250R	5.00 (127)	10.00 (254)	19.6 (489)
1300R	5.51 (140)	12.01 (305)	23.0 (584)
1375R	5.62 (143)	15.00 (381)	25.7 (653)
2000R	6.26 (159)	18.00 (457)	30.3 (770)
2400R	6.38 (162)	20.00 (508)	34.5 (876)
3500R	8.00 (203)	24.20 (615)	41.0 (1041)
5000R	10.12 (257)	27.20 (691)	47.0 (1194)
5500R	10.12 (257)	27.20 (691)	47.0 (1194)

### Selection Procedure

#### Conveyors

There are basically two ways to size conveyor backstops or holdbacks, either according to CEMA (Conveyor Equipment Manufacturers Association) standards or based on motor breakdown/stall torque values. Formsprag recommends that the selection be made on whichever value is greater.

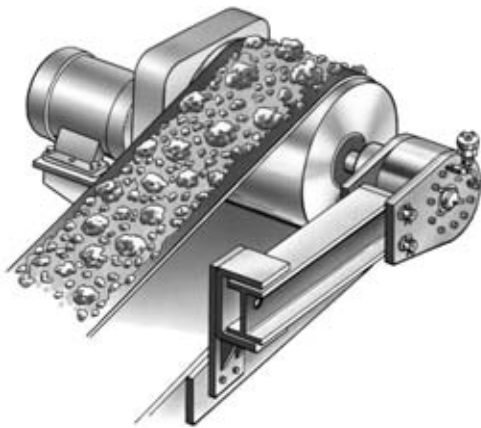

#### CEMA Formula:

The CEMA formula allows the design engineer to consider friction as a partial aid in preventing reverse rotation, thus reducing the torque capacity required for the clutch. Selection by this method does require the use of a service factor (S.F.). The basic CEMA formula for design torque is:

$$T_{\text{CEMA}} (\text{lb.ft.}) = \frac{(\text{S.F.}) (\text{Lift HP} - 1/2 \text{ Friction HP}) (5,250)}{(\text{Headshaft RPM})}$$

Formsprag recommends a minimum service factor of 1.5 when sizing with this formula. See worksheet, page 75.

#### Motor Breakdown or Stall Torque Formula:

Motor breakdown or stall torque could be imposed on the backstop if the conveyor is jammed or frozen, or when the conveyor is overloaded. In this condition the motor will produce stall torque which is significantly higher than the motor nameplate rating. This will cause the belt to stretch; and when the motor stalls, the stall torque produced by the motor will be imposed on the backstop. This torque will be increased if there is a load on the belt. Therefore, the maximum loading on a backstop occurs in the rare case of a moving belt being gradually overloaded until the motor reaches stall or breakdown torque. The torque on the backstop will be the motor torque from the stretched belt plus the torque from the load moving in the reverse direction due to the force of gravity.

To select a holdback based on motor breakdown torque, calculate motor torque using the following formula:

$$T_{\text{motor}} (\text{lb.ft.}) = \frac{(\text{S.F.}) (\text{Motor Nameplate HP}) (5,250)}{(\text{Headshaft RPM})}$$

The clutch may be selected on the basis of installed nameplate horsepower without using a service factor (S.F.), provided the motor breakdown torque does not exceed 175 percent of the nameplate rating; a minimum service factor based upon the ratio of motor breakdown torque to 175 percent of nameplate torque is required in order to preclude serious damage to the installation or to the holdback.

#### Torque Limiting Device:

If a torque limiting device is used and is less than 175 percent of the motor nameplate torque, then the holdback selected should have a capacity not less than 1.5 times the CEMA runback torque.

#### Bucket Elevators

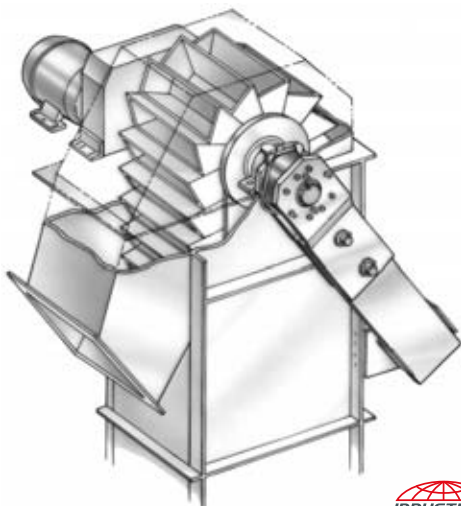

When selecting and sizing long life holdbacks application on bucket elevators, friction may or may not be considered because it is usually only a small fraction of the lift HP required. Similarly, motor breakdown HP is usually not considered if traction wheel drives are used because the elevator will usually slip before the breakdown HP is reached. For these reasons, the recommended design torque is based on lift HP alone.

$$T_B (\text{lb.ft.}) = \frac{(\text{S.F.}) (\text{Lift HP}) (5,250)}{(\text{Headshaft RPM})}$$

A minimum service factor (S.F.) of 2.0 is recommended. If additional assistance is needed, consult Formsprag Application Engineering.

**Speed and Idler Factors**

**Conveyors under 500' in length**

Based on:

Material Weight (W)

Total Lift (H)

Conveyor Length (L)

F = Speed factor for empty belt

C = Idler factor for loaded belt

Factor used depends on H/L Ratio

(Sine of Angle of Slope)

Belt Width	Material Weight (lb.ft.3)												H/L (Ratio)	
	30 lbs.		50 lbs.		75 lbs.		100 lbs.		130 lbs.		200 lbs.			
	F	C	F	C	F	C	F	C	F	C	F	C		
18"	.017	.050	.017	.050	.018	.050	.018	.050	.018	.050	.020	.037	.0	-.105
	.015	.040	.015	.040	.016	.040	.016	.040	.018	.034	.020	.033	.105	-.310
24"	.021	.050	.020	.043	.020	.045	.020	.041	.020	.045	.022	.037	.0	-.105
	.020	.035	.019	.033	.019	.033	.020	.030	.020	.030	.020	.030	.105	-.310
30"	.025	.044	.025	.043	.022	.037	.022	.041	.025	.038	.022	.037	.0	-.105
	.024	.030	.025	.028	.022	.028	.023	.025	.025	.025	.025	.025	.105	-.310
36"	.030	.040	.030	.038	.030	.037	.030	.038	.032	.038	.030	.039	.0	-.105
	.027	.030	.027	.030	.027	.030	.027	.030	.032	.029	.030	.023	.105	-.310
42"	.030	.040	.036	.036	.030	.040	.030	.040	.036	.040	.038	.040	.0	-.105
	.031	.030	.031	.030	.035	.027	.036	.027	.036	.027	.038	.027	.105	-.310
48"	.038	.036	.038	.038	.038	.039	.043	.038	.045	.040	.052	.044	.0	-.105
	.038	.030	.038	.030	.040	.027	.043	.027	.043	.027	.052	.027	.105	-.310
54"	.040	.037	.040	.040	.045	.042	.046	.042	.050	.047	—	—	.0	-.105
	.040	.030	.041	.028	.047	.028	.051	.028	.051	.030	—	—	.105	-.310
60"	.042	.037	.042	.040	.052	.045	.052	.049	—	—	—	—	.0	-.105
	.042	.030	.042	.028	.052	.029	.052	.030	—	—	—	—	.105	-.310

**Worksheet—CEMA Formula**

Holdback torque calculations are based on lift HP minus one-half friction HP. Equations are condensed and constants are tabulated as shown above.

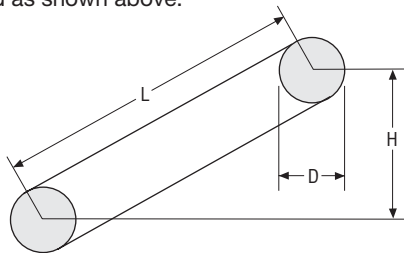

**Data**

- Conveyor Length L = \_\_\_\_\_ feet
- Belt Speed S = \_\_\_\_\_ FPM
- Short Tons Per Hour W = \_\_\_\_\_ TPH
- Total Lift H = \_\_\_\_\_ feet
- Headshaft Pulley Diameter D = \_\_\_\_\_ feet
- Belt Width = \_\_\_\_\_ inches
- Material Weight = \_\_\_\_\_ lb./ft.<sup>3</sup>
- Speed Factor F = \_\_\_\_\_
- Idler Factor C = \_\_\_\_\_
- Service Factor = \_\_\_\_\_ (1.5 minimum)

**Calculations**

Enter the data into these equations and perform the calculations following the sample worksheet.

(1) Power to lift load (P1):

$$P1 = \frac{WH}{990} = \frac{(\quad)(\quad)}{990} = \quad \text{HP}$$

(2) Power to move empty belt and idlers (P2):

$$P2 = \frac{.5LSF}{1,000} = \frac{.5(\quad)(\quad)(\quad)}{1,000} = \quad \text{HP}$$

(3) Power to move loaded belt (P3):

$$P3 = \frac{.5LWC}{990} = \frac{.5(\quad)(\quad)(\quad)}{990} = \quad \text{HP}$$

(4) Total Holdback Power (HBP) = P1 + P2 + P3 = \_\_\_\_\_ HBP

(5) Holdback Torque (T<sub>cema</sub>) =  $\frac{(\text{HBP})(\pi D) 5,250}{S}$  x Service Factor

$$T_{cema} = \frac{(\quad)(\quad)(5,250)}{(\quad)} = \quad \text{lb.ft.}$$

### Torque Arm Installation

The torque arm reaction force is the force which the torque arm stops must resist. Formsprag recommends that the stops be at least 3/4 of the distance (B) away from the center line of the clutch.

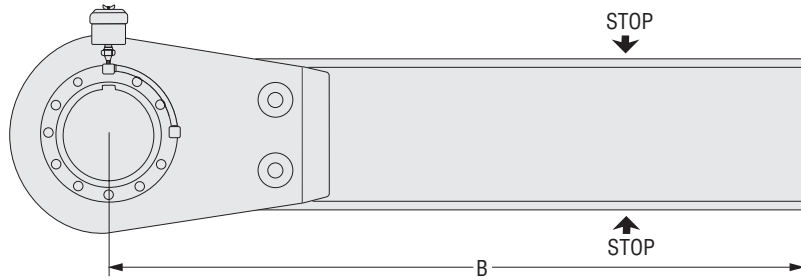

The torque arm reaction force is calculated as follows:

$$\text{Torque Arm Reaction—lbs. (kg)} = \frac{\text{*Rated Backstopping Torque—lb.ft. (Nm)}}{\text{Distance (.75B) of stop from centerline—ft. (m)}}$$

**Note:** Do not restrict torque arm movement in the axial direction.

\*Ratings are shown on page 65 of catalog for applicable holdback.

### Torque Arm Clearance

Torque arm clearance is required on all sides of the torque arm to prevent binding which could cause uneven loading of the holdback bearings.

**Note:** The torque arm must not be rigidly fastened at reaction point.

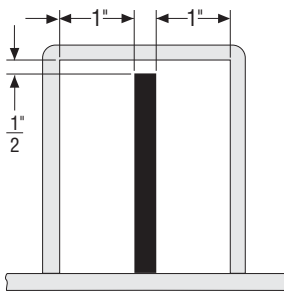

Models 700 thru 1027

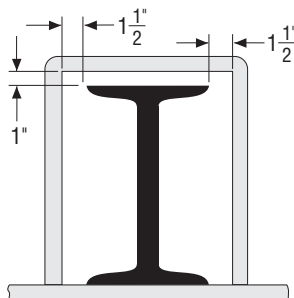

Models 1051 thru 5000

### Specifications

Size	B ft. (m)	.75B ft. (m)	Catalog Torque Values lb.ft. (Nm)	Torque Arm Reaction lb. (kg)
700S	2.5 (.76)	1.88 (.57)	4,000 (5424)	2,150 (975)
750S	2.67 (.81)	2.00 (.61)	6,800 (9221)	3,400 (1542)
800S	2.67 (.81)	2.00 (.61)	11,500 (15594)	5,750 (2608)
900S	3.67 (1.12)	2.75 (.84)	18,000 (24408)	6,550 (2970)
1027S	5.16 (1.57)	3.87 (1.18)	27,000 (36612)	7,000 (3175)
1051S	5.09 (1.55)	3.82 (1.16)	45,000 (61020)	12,000 (5443)
1250S	5.50 (1.68)	4.13 (1.26)	65,000 (88140)	15,750 (7145)
1250R	6.5 (1.98)	4.87 (1.48)	63,000 (85417)	12,936 (7145)
1300S	5.58 (1.71)	4.19 (1.28)	90,000 (122040)	21,500 (9750)
1300R	6.8 (2.0)	5.1 (1.5)	90,000 (122040)	17,647 (9750)
1375S	5.83 (1.78)	4.38 (1.34)	135,000 (183060)	31,000 (14060)
1375R	7.3 (2.2)	5.4 (1.65)	135,000 (183060)	25,000 (14060)
2000S	6.83 (2.08)	5.12 (1.56)	200,000 (271200)	39,500 (17917)
2000R	7.5 (2.3)	5.85 (1.72)	180,000 (244047)	30,770 (17917)
2400S	6.88 (2.10)	5.16 (1.57)	265,000 (359340)	51,500 (23360)
2400R	8.3 (2.5)	6.2 (1.87)	240,000 (325396)	38,700 (23360)
3500S	6.88 (2.10)	5.16 (1.57)	375,000 (508500)	68,000 (30844)
3500R	10 (3.0)	7.5 (2.25)	375,000 (508500)	50,000 (30844)
5000S	6.88 (2.10)	5.16 (1.57)	700,000 (949200)	136,250 (61800)
5000R	12 (3.6)	9 (2.7)	540,000 (732146)	60,000 (27272)
5000R	12 (3.6)	9 (2.7)	720,000 (979270)	80,000 (36363)



INDUSTRIAL MAGZA (3.6) MEX (55) 53 63 23 31 MTY (81) 89 52 70 18

QRO (442) 1 95 72 60 ventas@industrialmagza.com

Warner Electric/Formsprag (800-927-3262) www.formsprag.com



### OSHA Cover Kit

End cover kits for shaft end mounted LLH units are available from Formsprag. These cover kits provide not only the stationary cover enclosure required by OSHA, but additional protection for the LLH from abrasive environments as well.

**Note:** OSHA requires that clutches with projecting parts (and operating seven (7) feet or less above the floor) must be enclosed by a stationary guard (see below). Also, shaft couplings with bolts, nuts and set screws must be covered with safety sleeves unless they are counter sunk or do not extend beyond the flange of the coupling (see below).

(k) *Guarding of clutches, cutoff couplings, and clutch pulleys*—(1) Guards. Clutch cutoff couplings, or clutch pulleys having projecting parts, where such clutches are located seven (7) feet or less above the floor or less above the floor or working platform, shall be enclosed by a stationary guard constructed in accordance with this section. A "U" type guard is permissible.

Size	End Cover Part No.	Dimension "A" Inches
LLH-700	CL-7891	2.00
LLH-750	CL-7892	2.00
LLH-800	CL-7893	2.00
LLH-900	CL-7894	2.00
LLH-1027	CL-7895	2.50
LLH-1051	CL-7896	2.50
LLH-1250	CL-7897	2.50
LLH-1300	CL-7898	2.50
LLH-1375	CL-7899	3.00
LLH-2000	CL-7900	3.00
LLH-2400	CL-7901	Consult Formsprag
LLH-3500	CL-7902	Consult Formsprag
LLH-5000	CL-7902	Consult Formsprag

(i)(2) *Couplings*. Shaft coupling shall be so constructed as to present no hazard from bolts, nuts, setscrews, or revolving surfaces. Bolts, nuts, and set screws will, however, be permitted where they are covered with safety sleeves or where they are used parallel with the shafting and are countersunk or else do not extend beyond the flange of the coupling.

FEDERAL REGISTER,  
VOL.36, NO. 105—  
SATURDAY, MAY 29, 1971

### Lubrication

LLH Clutches are normally oil lubricated, see the Installation and Maintenance Bulletin No. 2224 for Models 700 thru 1027 or Bulletin No. 2211 for Models 1051 thru 5000 for the list of approved lubricants.

#### Grease Recommended for Long Life Holdbacks

Grease is recommended for vertical shaft applications, but it is not to be used where ambient temperatures are below +20°F. Below +20°F, consult Formsprag.

#### Storage

Formsprag LLH's are shipped 3/4 full of oil and ready for operation. If the clutch is to be stored for a long period of time (6 months to 2 years), it must be completely filled with oil (Mobil Artic "C") and stored under a roof at above freezing temperatures. At the customer's request, Formsprag will prepare the clutch for storage in accordance with our Spec SP-2700.

#### Oil Lubrication

The oil level should be checked weekly. To add oil, remove breather cover (entire breather on Model LLH-700), and pour oil into holdback.

Use a recommended oil for the permissible ambient temperature range as specified in the Installation and Maintenance Bulletin No. 2224 for Models 700 through 1027 or Bulletin No. 2211 for Models 1051 through 5000. Formsprag holdbacks are shipped three-fourths full of Mobil DTE Heavy Medium oil.

Holdbacks should be flushed every six months. If holdbacks operate under severe dust conditions, or 24 hours a day, flush every three months.

#### Auxiliary Seal Lubrication

Auxiliary seals should be lubricated every three months/monthly if clutch operates under extremely dusty conditions. To relubricate auxiliary seals, pump seals full, through all fittings on both sides, until old

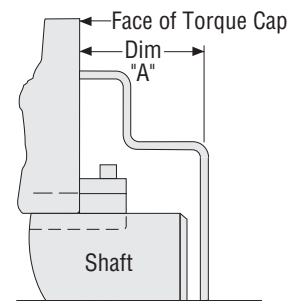

Sizes 700 through 1027

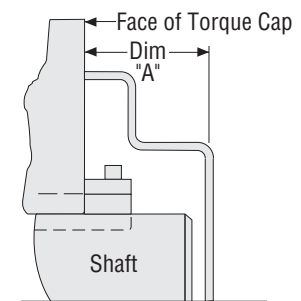

Sizes 1051 through 5000

grease is purged and clean grease runs out around the entire circumference of seal.

Use a grease selected from the Installation and Maintenance Bulletin No. 2224 for Models 700 through 1027 or Bulletin No. 2211 for Models 1051 through 5000. Auxiliary seals are packed with Mobil Oil SHC 32 grease prior to shipment.

For additional information, request *Lubrication & Maintenance Brochure A-4032* and *Installation & Maintenance Bulletin No. 2224* for Models 700 through 1027. For Models 1051 through 5000, request *Installation & Maintenance Bulletin No. 2211*.

### Bore sizes and shaft tolerances

#### English (inches)

Bore and shaft tolerances listed below will give the recommended fit for each size clutch. If the installation requirements make a press fit necessary, never exceed .001" interference fit. For all bore and shaft sizes not listed below use same tolerances and fits as next larger size.

Nominal Bore	Bore Diameter	Shaft Diameter
1.937	1.9385/1.9395	1.9375/1.9360
2.000	2.0010/2.0020	2.0000/1.9985
2.125	2.1260/2.1270	2.1250/2.1235
2.250	2.2510/2.2525	2.2500/2.2485
2.375	2.3760/2.3770	2.3750/2.3740
2.437	2.4385/2.4400	2.4375/2.4360
2.500	2.5010/2.5025	2.5000/2.4980
2.625	2.6260/2.6275	2.6250/2.6230
2.750	2.7510/2.7525	2.7500/2.7480
2.937	2.9385/2.9400	2.9375/2.9355
3.000	3.0010/3.0025	3.0000/2.9980
3.250	3.2510/3.2525	3.2500/3.2470
3.437	3.4385/3.4400	3.4375/3.4345
3.500	3.5010/3.5025	3.5000/3.4970
3.750	3.7510/3.7525	3.7500/3.7470
3.937	3.9385/3.9400	3.9375/3.9345
4.000	4.0010/4.0025	4.0000/3.9970
4.250	4.2510/4.2530	4.2500/4.2460
4.437	4.4385/4.4405	4.4375/4.4335
4.500	4.5010/4.5030	4.5000/4.4960
4.750	4.7510/4.7530	4.7500/4.7460
4.937	4.9385/4.9405	4.9375/4.9335
5.000	5.0010/5.0030	5.0000/4.9960
5.250	5.2510/5.2530	5.2500/5.2460
5.437	5.4385/5.4405	5.4375/5.4335
5.500	5.5010/5.5030	5.5000/5.4960
5.750	5.7510/5.7530	5.7500/5.7460
5.937	5.9385/5.9405	5.9375/5.9335
6.000	6.0020/6.0040	6.0000/5.9960
6.250	6.2520/6.2540	6.2500/6.2460
6.437	6.4390/6.4410	6.4375/6.4335
6.500	6.5020/6.5040	6.5000/6.4960
6.750	6.7520/6.7540	6.7500/6.7460
6.937	6.9400/6.9420	6.9375/6.9335

**Note:** On models 750 through 5000, Formsprag may elect to supply a stepped key in the event of keyseat distortion during heat treat of inner race.

For bore sizes and recommended shaft tolerances for all other clutch series see page 120.

Nominal Bore	Bore Diameter	Shaft Diameter
7.000	7.003/7.005	7.001/7.000
7.500	7.504/7.506	7.502/7.501
7.750	7.754/7.756	7.752/7.751
8.000	8.004/8.006	8.002/8.001
8.250	8.254/8.256	8.252/8.251
8.500	8.504/8.506	8.502/8.501
8.750	8.754/8.756	8.752/8.751
9.000	9.004/9.006	9.002/9.000
9.250	9.254/9.256	9.252/9.250
9.500	9.504/9.506	9.502/9.500
9.750	9.754/9.756	9.752/9.750
10.000	10.004/10.006	10.002/10.000
10.500	10.504/10.506	10.502/10.500
11.000	11.004/11.006	11.002/11.000
11.500	11.504/11.506	11.502/11.500
12.000	12.004/12.006	12.002/11.999
12.250	12.254/12.256	12.252/12.249
12.500	12.504/12.506	12.502/12.499
13.000	13.004/13.006	13.002/12.999
13.250	13.254/13.256	13.252/13.249
13.500	13.504/13.506	13.502/13.499
13.750	13.754/13.756	13.752/13.749
14.000	14.004/14.006	14.002/13.999
14.250	14.254/14.256	14.252/14.249
14.500	14.504/14.506	14.502/14.499
14.750	14.754/14.756	14.752/14.749
15.000	15.004/15.006	15.002/14.999
15.250	15.254/15.256	15.252/15.249
15.500	15.504/15.506	15.502/15.499
15.750	15.754/15.756	15.752/15.749
16.000	16.004/16.007	16.002/16.000
16.250	16.254/16.257	16.252/16.250
16.500	16.504/16.507	16.502/16.500
16.750	16.754/16.757	16.752/16.750
17.000	17.004/17.007	17.002/17.000
17.250	17.254/17.257	17.252/17.250
17.500	17.504/17.507	17.502/17.500
17.750	17.754/17.757	17.752/17.750
18.000	18.004/18.007	18.002/18.000
18.250	18.254/18.257	18.252/18.250
18.500	18.504/18.507	18.502/18.500
18.750	18.754/18.757	18.752/18.750
19.000	19.004/19.007	19.002/19.000
20.000	20.004/20.007	20.002/20.000

**Metric (millimeters)**

Bore and shaft tolerances listed below will give the recommended fit for each size clutch. If the installation requirements make a press fit necessary, never exceed .025 mm interference fit. For all bore and shaft sizes not listed below use same tolerances and fits as next larger size.

For metric bores the recommended bore tolerances are F7.

Nominal Bore	Bore Diameter	Shaft Diameter
49.20	49.24/49.26	49.21/49.17
50.80	50.83/50.85	50.80/50.76
53.98	54.00/54.03	53.97/53.94
57.15	57.18/57.21	57.15/57.11
61.90	61.94/61.98	61.91/61.87
63.50	63.53/63.56	63.50/63.45
66.68	66.70/66.74	66.68/66.62
69.85	69.88/69.91	69.85/69.80
74.60	74.64/74.68	74.61/74.56
76.20	76.23/76.26	76.20/76.15
82.55	82.58/82.61	82.55/82.47
87.30	87.34/87.38	87.31/87.24
88.90	88.92/88.96	88.90/88.82
95.25	95.28/95.31	95.25/95.17
100.00	100.04/100.08	100.01/99.94
101.60	101.63/101.66	101.60/101.52
107.95	107.98/108.03	107.95/107.88
112.70	112.74/112.79	112.71/112.61
114.30	114.33/114.38	114.30/114.20
120.65	120.68/120.73	120.65/120.55
125.40	124.44/125.49	125.43/125.31
127.00	127.03/127.08	127.00/126.90
133.35	133.38/133.43	133.35/133.25
138.10	138.14/138.19	138.11/138.01
139.70	139.72/139.78	139.70/139.60
146.05	146.08/146.13	146.05/145.95
150.80	150.84/150.89	150.81/150.71
152.40	152.45/152.50	152.40/152.30
158.75	158.80/158.85	158.75/158.65
163.50	163.55/163.60	163.51/163.41
165.10	165.15/165.20	165.10/164.10
171.45	171.50/171.55	171.45/171.35
176.20	176.28/176.33	176.21/176.11

**Note:** On models 750 thru 5000, Formsprag may elect to supply a stepped key in the event of keyseat distortion during heat treat of inner race.

For bore sizes and recommended shaft tolerances for all other clutch series see page 121.

Nominal Bore	Bore Diameter	Shaft Diameter
177.80	177.88/177.93	177.83/177.80
190.50	190.60/190.66	190.55/190.53
196.85	196.95/197.00	196.90/196.88
203.20	203.30/203.35	203.25/203.23
209.55	209.65/209.70	209.60/209.58
215.90	216.00/216.05	215.95/215.93
222.25	222.35/222.40	222.30/222.28
228.60	228.70/228.75	228.65/228.60
234.95	235.05/235.10	235.00/234.95
241.30	241.40/241.45	241.35/241.30
247.65	247.75/247.80	247.70/247.65
254.00	254.10/254.15	254.05/254.00
266.80	266.80/266.85	266.75/266.70
279.40	279.50/279.55	279.45/279.40
292.10	292.20/292.25	292.15/292.10
304.80	304.90/304.95	304.85/304.77
311.15	311.25/311.30	311.20/311.12
317.50	317.60/317.65	317.55/317.47
330.20	330.30/330.35	330.25/330.17
336.55	336.65/336.70	336.60/336.52
342.90	343.00/343.05	342.95/342.87
349.25	349.35/349.40	349.30/349.22
355.60	355.70/355.75	355.65/355.57
361.95	362.05/362.10	362.00/361.92
368.30	368.40/368.45	368.35/368.27
374.65	374.75/373.80	374.70/374.62
381.00	381.10/381.15	381.05/380.97
387.35	387.45/387.50	387.40/387.32
393.70	393.80/393.85	393.75/393.67
400.05	400.15/400.20	400.10/400.02
406.40	406.50/406.58	406.45/406.40
412.75	412.85/412.93	412.80/412.75
419.10	419.20/419.28	419.15/419.10
425.25	425.55/425.63	425.50/425.45
431.80	431.90/431.98	431.85/431.80
438.15	438.25/438.33	438.20/438.15
444.50	444.60/444.68	444.55/444.50
450.85	450.95/451.01	450.90/450.85
457.20	457.30/457.38	457.25/457.20
463.55	463.65/463.73	463.60/463.55
469.90	470.00/470.08	469.95/469.90
476.25	476.35/476.43	476.30/476.25
482.60	482.70/482.78	482.65/482.60
508.00	508.10/508.18	508.05/508.00

